

Mi-T-M[®] CORPORATION

8650 Enterprise Drive, Peosta IA 52068

563-556-7484 / Fax 563-556-1235

PARTS LIST FOR
HSP-2403-3MGH
(After Serial #26203)

HONDA OIL GRADE:	SAE 10W-30
HONDA OIL CAPACITY:	20 OZ.
PUMP OIL GRADE:	Mi-T-M PUMP OIL AW-4085-0016
PUMP OIL CAPACITY:	14 OZ.
FUEL NOZZLE:	1.25 60°B DELAVAN
BTU INPUT:	205,000 / HOUR
PRESSURE NOZZLE SIZE:	3.0

This Parts Listing has been compiled for your benefit. You can be assured your hot water pressure washer was constructed and designed with quality and performance in mind. Each component has been rigorously tested to insure the highest level of quality.

The contents of this Parts Listing are based on the latest product information available at the time of publication. The manufacturer reserves the right to make changes in price, color, materials, equipment, specifications or models at any time without notice.

WARNING

THIS IS A PROFESSIONAL HIGH PRESSURE, HOT WATER PRESSURE WASHER. CAUTION SHOULD BE OBSERVED WHEN USING OR REPAIRING THIS UNIT! READ AND FOLLOW THE SAFETY WARNINGS LISTED BELOW BEFORE ATTEMPTING ANY REPAIRS ON THIS PRESSURE WASHER!

SAFETY WARNINGS

1. NEVER alter or modify the equipment. Be sure any accessory items and system components being used will withstand the pressure developed. Use only genuine manufacturer parts for repair of your pressure washer. Failure to do so can cause hazardous operating conditions and will VOID warranty.
2. NEVER make adjustments on machinery while the unit is connected to the engine without first removing the ignition cable from the spark plug. Turning over the machinery by hand during adjustment or cleaning might start the engine and machinery with it, causing serious injury to the operator.
3. Know how to stop and bleed pressures quickly. Be thoroughly familiar with controls.
4. Before servicing the unit, turn unit off, relieve the water pressure and allow the unit to cool down. Do not make repairs while the unit is running. Service in a clean, dry, flat area. Block the wheels to prevent the unit from moving. Be especially careful to properly dispose of any flammable materials.
5. After testing the machine, DO NOT leave the pressurized unit unattended. Shut off the unit and release trapped pressure before leaving.

Table of Contents

SPECIFICATIONS 3
FLOW CHART 4
EMF SYSTEM 4
GENERAL THEORY OF OPERATION 5
DECAL PLACEMENT 6
UNLOADER (850-0252) 16
PRESSURE SWITCH (22-0171) 18
DETERGENT INJECTOR (50-0052) 20
COIL DRAIN PLUG (850-0218) 21
HEAT EXCHANGER/EMF SYSTEM 22
BOILER ASSEMBLY (850-0224) 24
GUN (850-0179) & ADJUSTABLE PRESSURE DUAL LANCE (850-0185) 26
FUEL TANK (850-0214) 28
FUEL PUMP (3-0129) 30
FUEL SOLENOID (44-0098) 31
EMF SYSTEM (850-0239) 32
WIRING SCHEMATIC 34
WIRING DIAGRAM 35

SPECIFICATIONS

HSP-2403-3MGH

MODEL NUMBER	HSP-2403-3MGH
Operating Pressure (PSI/Bar):	2400/ 165 (+/- 5%)
Water Volume (GPM/lpm):	2.3/8.7 (+/- 5%)
Outlet Water Temperature (F/C):	130 F/ 54 C (+/- 20 F) rise above inlet ambient (210 F/ 99 C maximum)
Engine:	Honda
Horsepower	6.5
Engine Type	Four Stroke, Overhead Valve, Single Cylinder
Oil Type	SAE 10W-30
Oil Capacity (oz./liter)	20/6
Low Oil Protection	Oil Alert
Fuel Type	Unleaded Gasoline 86 Octane Minimum
Fuel Capacity (gal./liter)	.95/3.6
Starting	Recoil Rope
Maximum No Load RPM	3600 (+/- 100)
High Pressure Pump:	Direct Driven, Oil Bath, Triplex Piston
Oil Type	Mi-T-M Pump Oil #AW-4085-0016
Oil Capacity (oz./liters)	14/41
Plungers	Ceramic
Manifold	Forged Brass
Valves	Stainless Steel
Unloader	Preset
Inlet Water Strainer	Removable Clear Bowl for inspection and cleaning of Stainless Steel Screen
Heat Dump Valve	Relieves heated water during unloader bypass stage
Detergent Injector:	Adjustable Low Pressure downstream from pump
Burner Fuel System:	
Fuel Type	No.1 or No.2 Fuel Oil, Diesel or Kerosene
Fuel Capacity (gal./liters)	4/15
Fuel Filter/ Water Separator	Spin on (10 micron) filter/ E-Z water drain
Fuel Pump	Two Line, Single Stage
Fuel Pressure (PSI/ BAR)	145/10
Fuel Nozzle	1.25 60 B Delavan
Fuel Consumption (GPH/ LPH)	1.48 GPH Continous Burning
Electro Magnetic Firing (EMF) System:	Belt Driven (Patent Pending)
Ignition	Transistorized Magneto
Control Voltage	12 Volt DC
Blower	Forced Air
Heat Exchanger:	Vertical, Top fired, Dual Spiral Coil
BTU Input	205,000
Efficiency	80-83% with #2 Fuel Oil/ Diesel
Smoke Density	0-3 per ASTM D2156
Controls:	
On/ Off Switch	Industrial grade cam switch
Pressure Switch	Shuts off burner fuel supply upon trigger release
High Limit Switch	Shuts off burner fuel supply when outlet water temp. exceeds 210 F/ 99 C
Fuel Solenoid:	12 Volt
Safety Relief:	Relieves excess system pressure
Unit Net Weight (Lbs/kg):	269/122
Unit Shipping Weight (Lbs/kg):	385/175
Unit Net Dimension (In/cm):	37.5Lx29.5Wx37.5H/95Lx75Wx95H
Unit Shipping Dimension (In/cm):	46.5Lx31.5Wx48.5H/118Lx80Wx123H

FLOW CHART

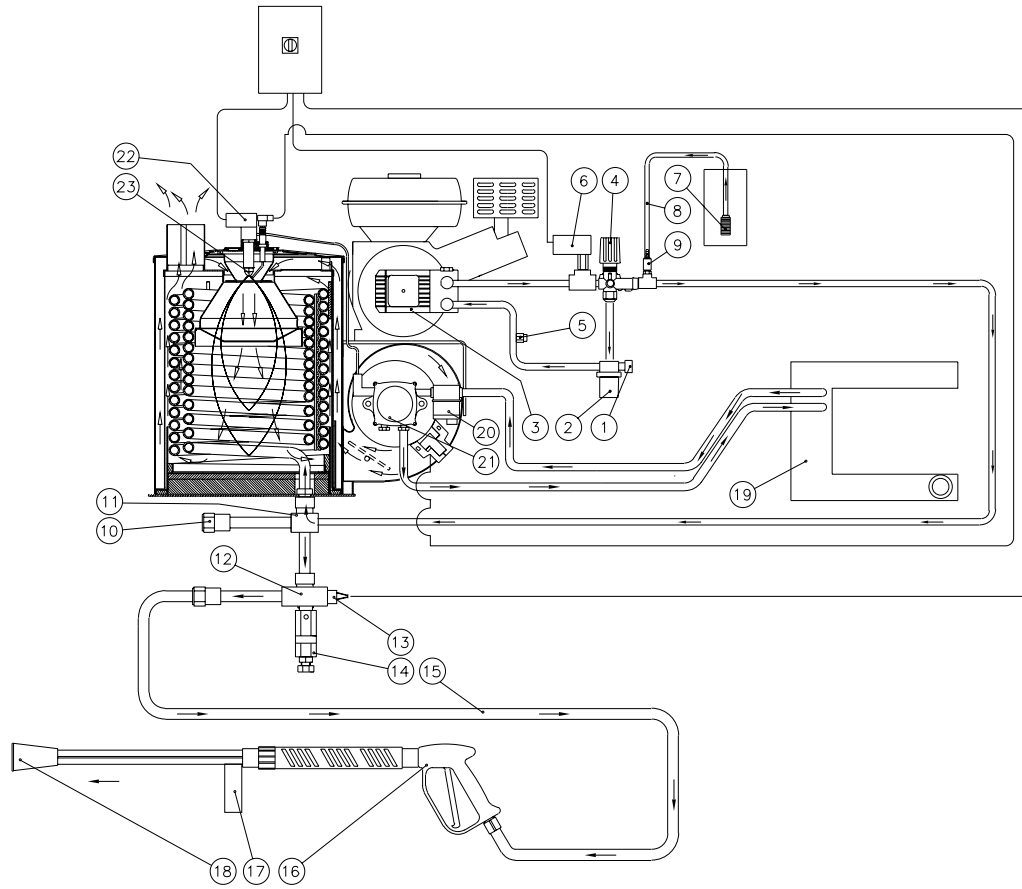

OMHSP091-120998-BAR

EMF SYSTEM

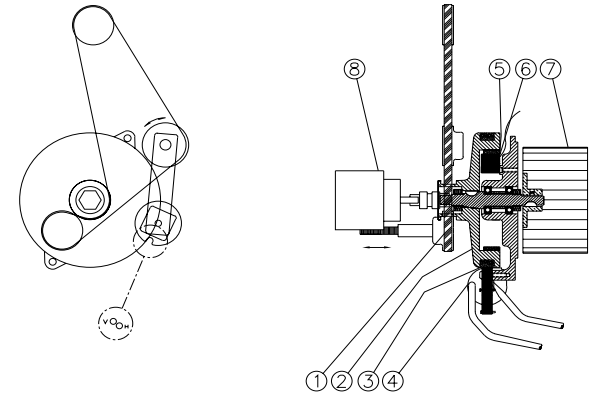

OMHSP008-012494-BAR

GENERAL THEORY OF OPERATION

WATER FLOW: Connect a pressurized water source to the INLET GARDEN HOSE CONNECTION (1) and turn on the water supply. The water will flow through a WATER STRAINER (2) which has a clear inspection bowl.

The water then travels into the TRIPLEX HIGH PRESSURE PUMP (3) which has an UNLOADER (4) that bypasses the water when the trigger gun is closed. To protect the pump from heated water during this bypass stage, a HEAT DUMP VALVE (5) will open at 140°F/60°C allowing the heated water to escape. The Heat Dump Valve automatically resets when the water cools. The PRESSURE SWITCH (6) controls the fuel supply to the burner.

When using detergents, the solution passes through the DETERGENT STRAINER (7) located on the DETERGENT HOSE (8). The detergent solution then travels into the ADJUSTABLE LOW PRESSURE DETERGENT INJECTOR (9).

From there, the water may be allowed to flow out of the DRAIN PLUG (10) or through the HEAT EXCHANGER INLET (11) where it is heated when the burner is on. As the water exits the HEAT EXCHANGER OUTLET (12), it enters a safety system which protects the operator from danger. The safety system contains a HIGH TEMPERATURE LIMIT SWITCH (13) which senses the water temperature and shuts off the fuel supply to the burner if it gets too hot. If the unloader fails to by pass the water or the burner remains on when the trigger gun is closed, the SAFETY RELIEF (14) will relieve and allow water to exit safely.

The heated water then flows through the HIGH PRESSURE HOSE (15) and to the TRIGGER GUN ASSEMBLY (16) which allows the operator to control the water spray. When the trigger gun is open, the water flows through the ADJUSTABLE PRESSURE DUAL LANCE (17) and exits the NOZZLE (18).

FUEL FLOW: The Fuel Pump draws fuel from the FUEL TANK (19) through a replaceable FUEL FILTER/WATER SEPARATOR (20) and into the FUEL PUMP (21). Fuel exits the fuel pump, into a FUEL SOLENOID VALVE (22) which controls fuel flow to the FUEL NOZZLE (23) where it ignites and burns in the heat exchanger.

EMF SYSTEM: The patent pending Electro Magnetic Firing (EMF) System is an integrated system which gives all the requirements for combustion.

The BELT (1) from the power source turns the HUB (2) which has two EXTERIOR MAGNETS (3) attached. As these magnets spin past the IGNITION MODULE (4), a magnetic flux is created from which the ignition module produces a high voltage. This voltage arcs across the electrodes giving the spark that is needed for ignition.

This hub has an INTERNALLY MOUNTED MAGNET (5) which spins past a STATOR (6) that produces the voltage that controls the fuel supply to the heat exchanger. In addition to this, the hub also spins the BLOWER FAN (7) that forces the air into and through the heat exchanger.

The FUEL PUMP (8) is also connected the hub by means of a flexible coupler.

DECAL PLACEMENT

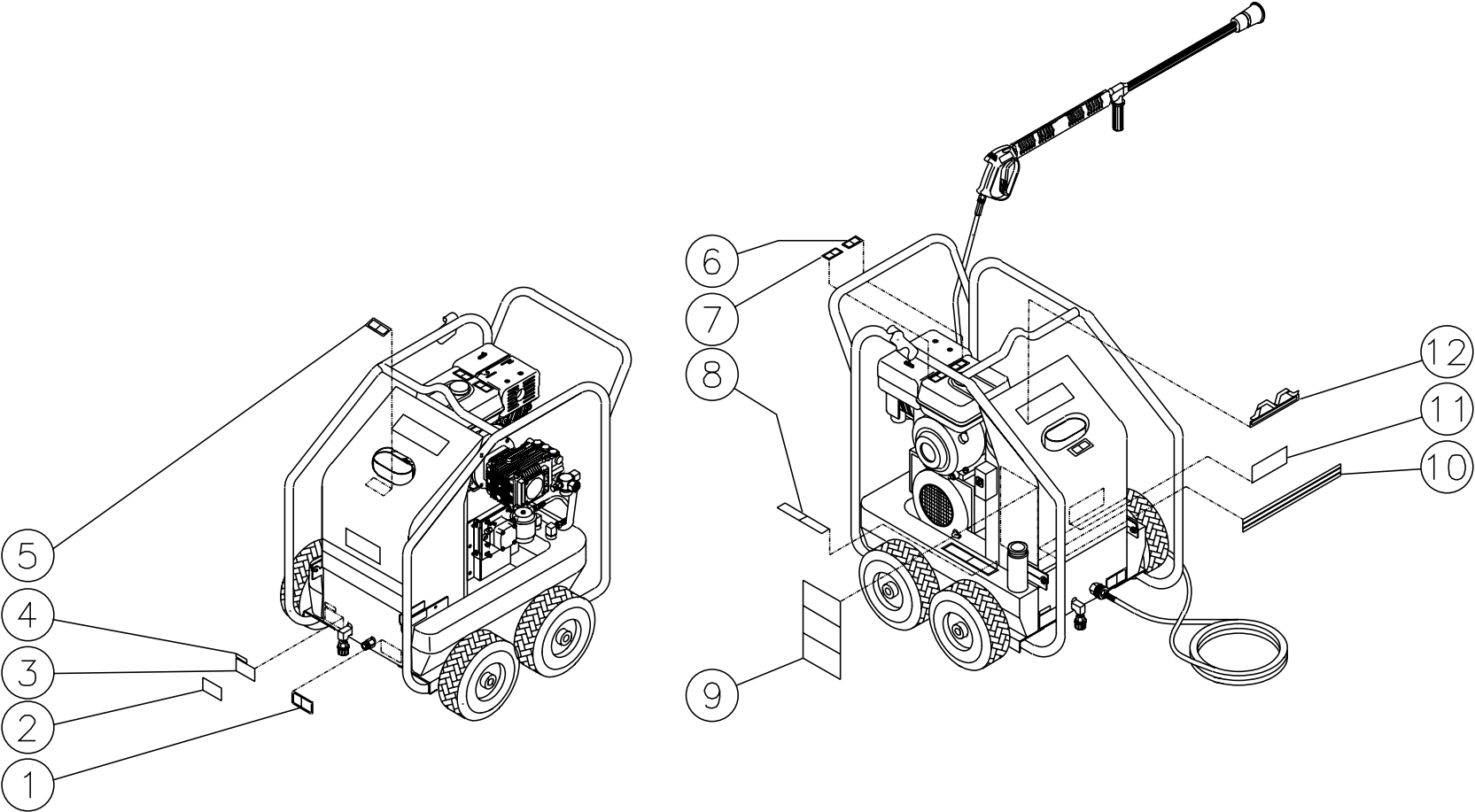

HSP-2403-3MGH-022399-BAR

DECAL PLACEMENT			
REF. #	DESCRIPTION	PART #	QTY.
1	Decal- Warning: Don't Modify Plumbing (E/S) (See 34-9001)	N/A Sep.	1
2	Decal- Clear Laminate	N/A	1
3	Decal- Data Plate	N/A	1
4	Serial Number	N/A	1
5	Decal- Warning: Hot Coil Exhaust (E/S) (See 34-9001)	N/A Sep.	1
6	Decal- Allow to Cool (E/S) (See 34-9001)	N/A Sep.	1
7	Decal- Hot Surface (E/S) (See 34-9001)	N/A Sep.	1
8	Decal- Risk of Fire (E/S) (See 34-9001)	N/A Sep.	1
9	Decal- Warning/ Caution/ Operation (E/S) (See 34-9001)	N/A Sep.	1
10	Decal- Stripe	34-0560	1
11	Decal-White Die Cut	34-0711	1
12	Plastic Mi-T-M Logo	62-0087	1
	Safety Decal Kit (Includes 1, 5-9)	34-9001	

FRAME

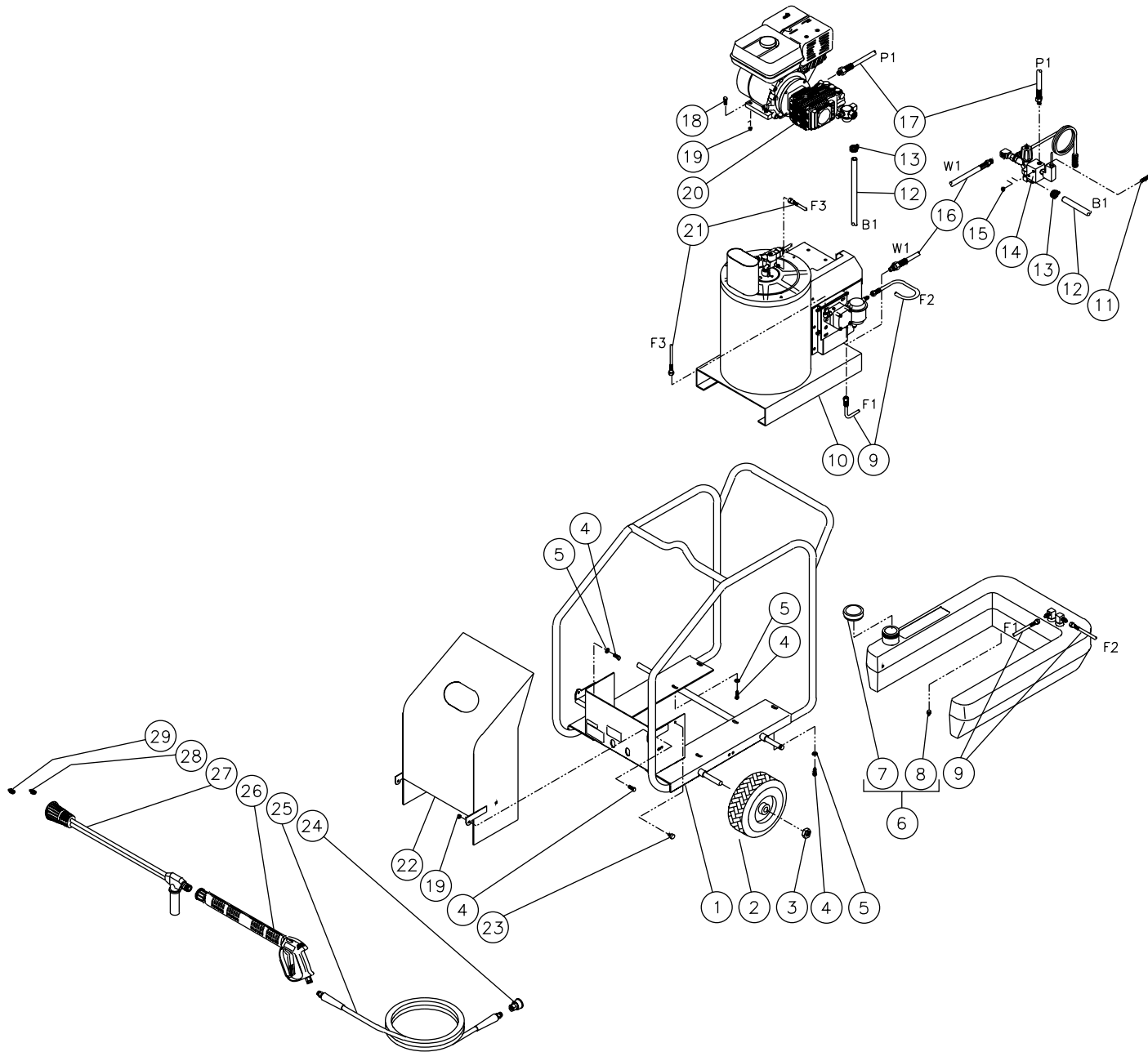

FRAME

REF. #	DESCRIPTION	PART #	QTY.	REF. #	DESCRIPTION	PART #	QTY.
1	Frame Assembly	5-9002A01	1	16	High Pressure Hose Assembly	15-0199	1
2	Wheel	14-0017	4	17	High Pressure Hose Assembly	15-0194	1
3	Jam Nut	30-0117	4	18	Bolt	27-9525	4
4	Bolt	27-9524	12	19	Hex Nut	30-3023	6
5	Flatwasher	28-0022	10	20	Engine/ Pump Assembly (See exploded drawing)	N/A Sep.	1
6	Fuel Tank Assembly (Includes 7, 8)	850-0214	1	21	Fuel Line	33-0217	1
7	Fuel Cap	12-0033	1	22	Hood Assembly	850-0164	1
8	Plug	23-0296	1	23	Screw Cover	62-0057	1
9	Fuel Hose	15-0147	2	24	Screw Connect	17-0035	1
10	Heat Exchanger/ EMF System Assembly (See exploded drawing)	N/A Sep.	1	25	Hose Assembly	15-0146	1
11	Bolt	27-0526	2	26	Gun/ Lance Assembly	850-0179	1
12	Hose *(Two Feet Required)	15-0007	1	27	Dual Lance Assembly- 36"	850-0185	1
13	Hose Clamp	42-0011	2	28	Nozzle- 1503	18-0053	1
14	Unloader/ Manifold Assembly (See exploded drawing)	N/A Sep.	1	29	Nozzle- 4060	18-0110	1
15	Hex Nut	30-0157	2	*Must Order in One Foot Lengths			

ENGINE/ PUMP ASSEMBLY

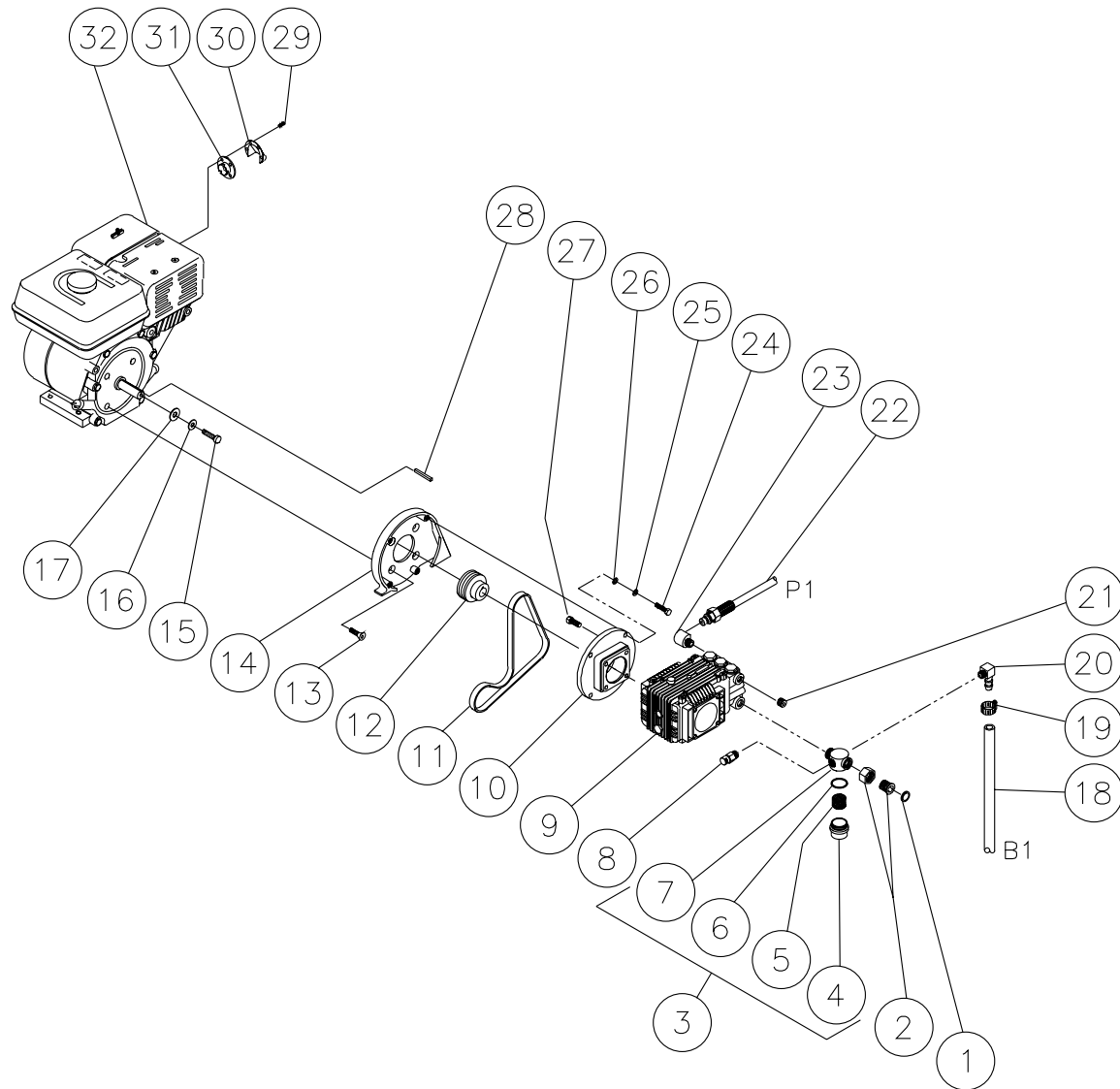

ENGINE/ PUMP ASSEMBLY							
REF. #	DESCRIPTION	PART #	QTY.	REF. #	DESCRIPTION	PART #	QTY.
1	Hose Gasket	26-0001	1	18	Hose *(Two Feet Required)	15-0007	1
2	Hose Swivel	23-0095	1	19	Hose Clamp	42-0011	1
3	Strainer Complete (Includes 4-7)	19-0096	1	20	Elbow	23-0119	1
4	Strainer Bowl	19-0103	1	21	Plug	23-0244	1
5	Screen	19-0104	1	22	High Pressure Hose	15-0194	1
6	Strainer Gasket	25-0056	1	23	Elbow	23-0034	1
7	Strainer Body	19-0105	1	24	Bolt	27-0118	4
8	Heat Dump Valve	22-0208	1	25	Lockwasher	29-0008	4
9	High Pressure Pump	3-0193	1	26	Flatwasher	28-0023	4
10	Flange/ Pump Adapter	38-0054	1	27	Bolt	27-8432	4
11	Belt	11-0037	1	28	Key	43-0073	1
12	Sheave	10-0076	1	29	Screw	27-3093	2
13	Bolt	27-0418	4	30	Muffler Deflector	45-0053	1
14	Adapter Plate	38-0044	1	31	Muffler Guide	21-0099	1
15	Bolt	27-0091	1	32	Engine- 6.5 H.P. Honda	1-0088	1
16	Lockwasher	29-0007	1	* Must Order in One Foot Lengths			
17	Flatwasher	28-0003	1				

HIGH PRESSURE PUMP (3-0193)

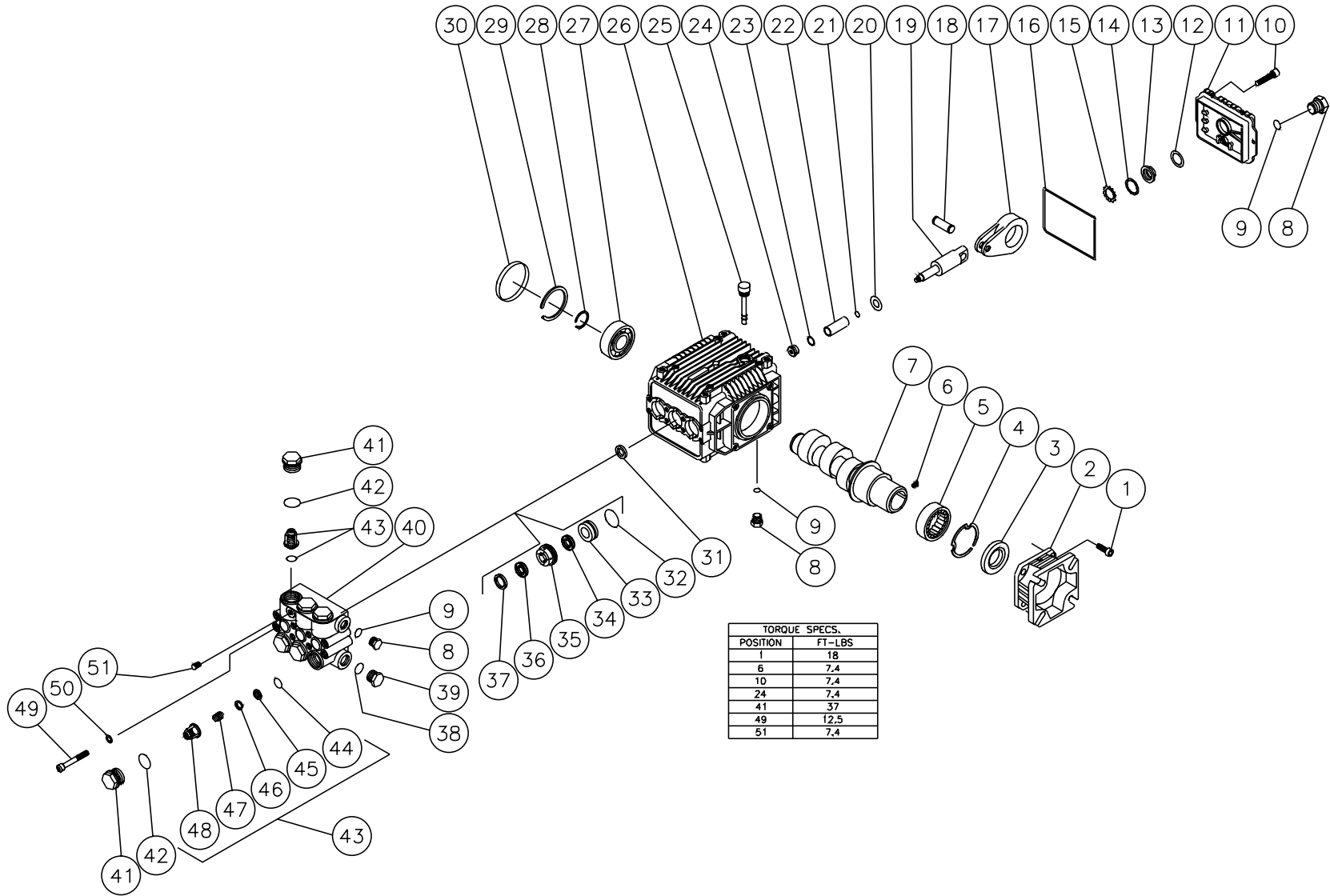

3-0193-021301-RD

HIGH PRESSURE PUMP (3-0193)

REF.	DESCRIPTION	PART #	QTY.	REF.	DESCRIPTION	PART #	QTY.	REF.	DESCRIPTION	PART #	QTY.
1	Bolt	27-8432	4	19	Plunger Rod	46-0722	3	37	Support Ring (See 70-0182)	N/A Sep.	3
2	Flange	46-0715	1	20	Washer	28-1027	3	38	O-ring	25-0372	1
3	Oil Seal	26-0192	1	21	O-ring	25-0371	3	39	Plug	39-0088	1
4	Retaining Ring	46-0667	1	22	Piston	46-0723	3	40	Manifold	46-0730	1
5	Bearing	48-0059	1	23	Washer	26-0187	3	41	Valve Cap	39-0087	6
6	Set Screw	27-8886	1	24	Nut	30-6016	3	42	O-ring	25-0160	6
7	Crankshaft	46-0718	1	25	Oil Dipstick	39-0090	1	43	Single Valve Assembly (Inc. 44-48) (See 70-0161)	N/A Sep.	6
8	Plug	39-0086	1	26	Crankcase	46-0724	1	44	O-ring (See 70-0161)	N/A Sep.	6
9	O-ring	25-0325	3	27	Bearing	48-0063	1	45	Valve Seat (See 70-0161)	N/A Sep.	6
10	Bolt	27-8888	6	28	Retaining Ring	46-0732	1	46	Valve Plate (See 70-0161)	N/A Sep.	6
11	Crankcase Cover	46-0719	1	29	Retaining Ring	46-0676	1	47	Valve Spring (See 70-0161)	N/A Sep.	6
12	O-ring	25-0370	1	30	Bearing Cap	46-0725	1	48	Valve Cage (See 70-0161)	N/A Sep.	6
13	O-ring Sight Glass	46-0670	1	31	Oil Seal	26-0193	3	49	Bolt	27-8875	8
14	Reflector	46-0824	1	32	O-ring	25-0399	3	50	Lockwasher	29-0153	8
15	Retainer	46-0671	1	33	Retainer	46-0726	3	51	Plug	39-0097	1
16	O-ring	25-0398	1	34	Low Pressure Seal (See 70-0181)	N/A Sep.	3		Seal Kit (3 each 32, 34, 36)	70-0181	
17	Connecting Rod	46-0720	3	35	Packing Retainer	46-0728	3		Support Rings (3 each 37)	70-0182	
18	Piston Pin	46-0721	3	36	V-Packing (See 70-0181)	N/A Sep.	3		Valve Kit (6 each 44-48)	70-0161	

UNLOADER/ MANIFOLD ASSEMBLY

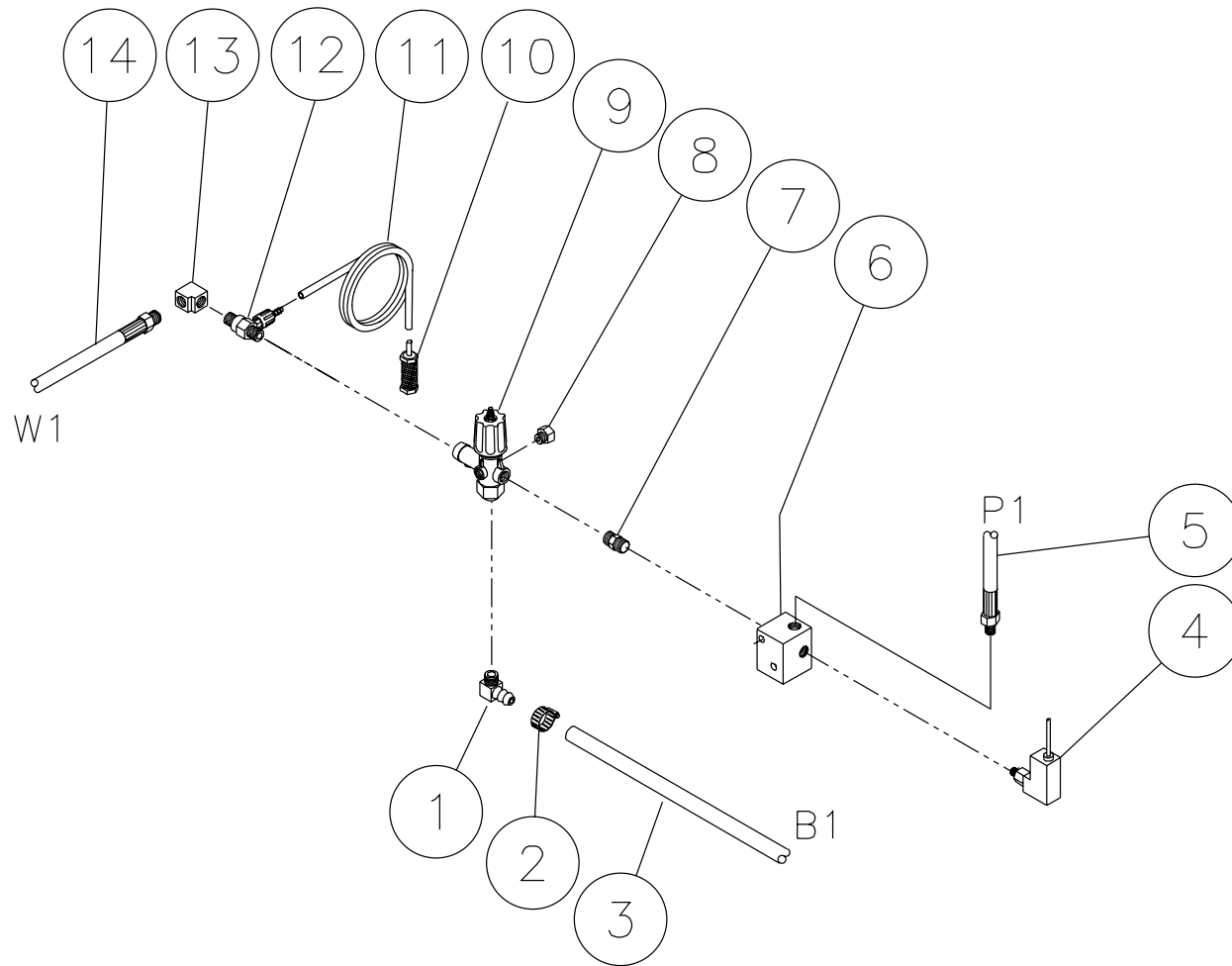

OMHSP088-3MDL-032900-BAR

UNLOADER/ MANIFOLD ASSEMBLY			
REF. #	DESCRIPTION	PART #	QTY.
1	Elbow	23-0119	1
2	Hose Clamp	42-0011	1
3	Hose *(Two Feet Required)	15-0007	1
4	Pressure Switch	22-0171	1
5	High Pressure Hose Assembly	15-0194	1
6	Manifold Block	51-0025	1
7	Hex Nipple	24-0010	1
8	Plug	23-0238	1
9	Unloader Assembly	850-0252	1
10	Detergent Stainer	19-0050	1
11	Detergent Hose *(Six Feet Required)	15-0021	1
12	Detergent Injector	50-0052	1
13	Elbow	23-0307	1
14	High Pressure Hose Assembly	15-0199	1
*Must Order in One Foot Lengths			

UNLOADER (850-0252)

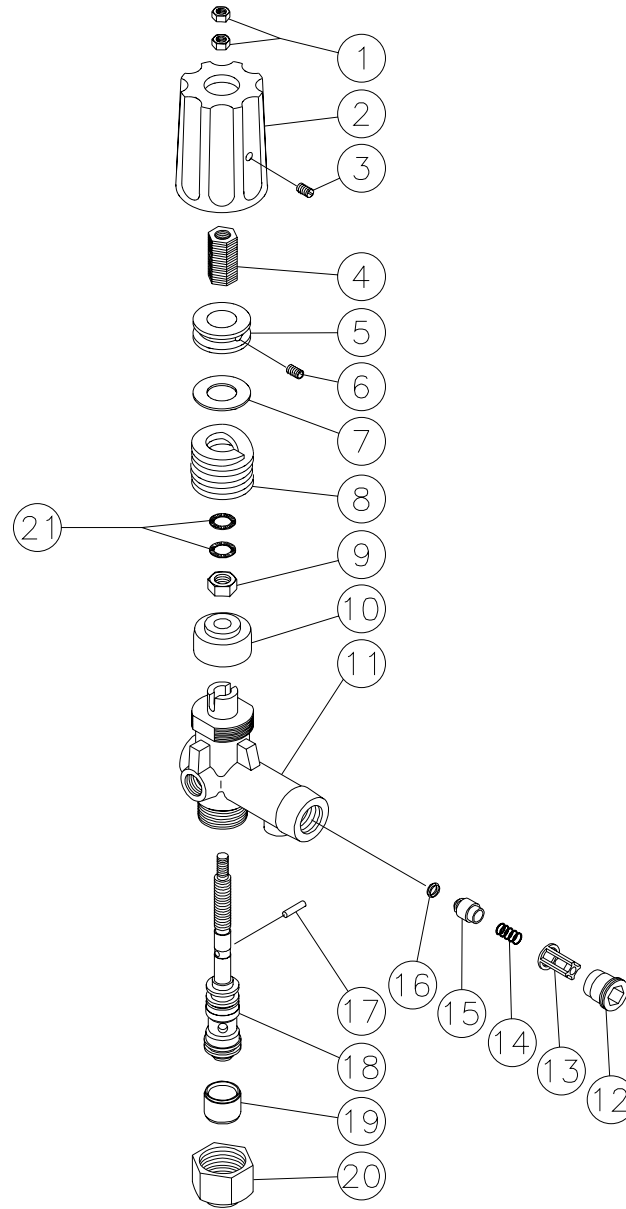

UNLOADER (850-0252)			
REF. #	DESCRIPTION	PART #	QTY.
1	Hex Nut	8-0362	2
2	Cover	7-0098	1
3	Set Screw	27-4280	1
4	Adjusting Insert- Brass	8-0363	1
5	Adjustment Nut	8-0364	1
6	Set Screw	8-0365	1
7	Glide Ring	8-0366	1
8	Spring	49-0104	1
9	Hex Nut	8-0367	1
10	Bushing	8-0368	1
11	Unloader Body	8-0369	1
12	Retainer	8-0269	1
13	Valve Housing	8-0104	1
14	Spring	49-0023	1
15	Valve	8-0105	1
16	O-ring	25-0036	1
17	Cylinder Pin	8-0372	1
18	Piston Repair Kit	70-0243	1
19	Spacer	8-0371	1
20	Stop Nut	8-0157	1
21	Washer	29-0154	2
	Check Valve Repair Kit (Includes 13-16)	70-0244	
	Unloader Complete	850-0252	

PRESSURE SWITCH (22-0171)

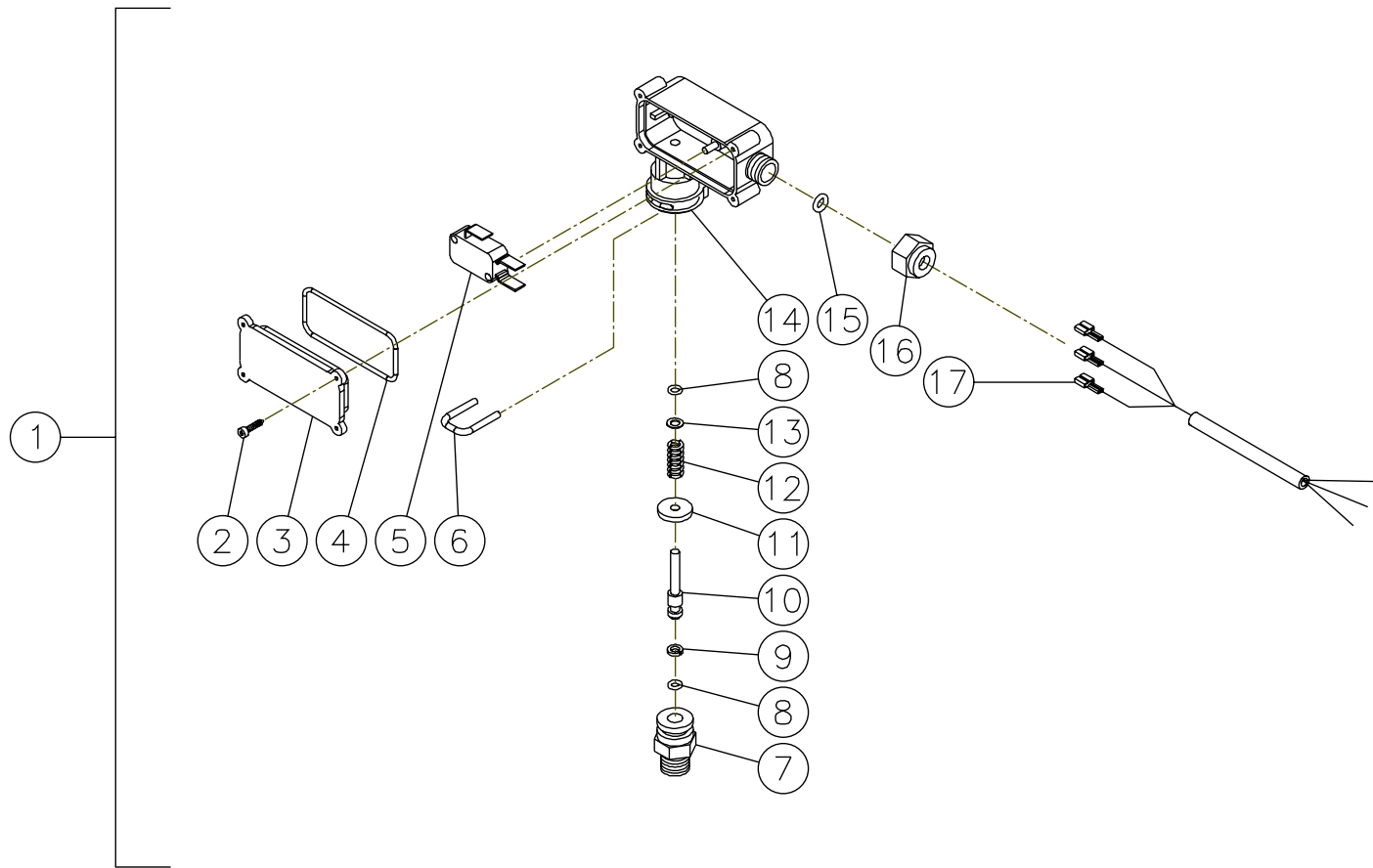

22-0171/22-0243-120799-BAR

22-0171-120799-BAR

PRESSURE SWITCH (22-0171)			
REF. #	DESCRIPTION	PART #	QTY.
1	Pressure Switch	22-0171	1
2	Screw	N/A	4
3	Cover	N/A	1
4	O-ring (See 70-0306)	N/A Sep.	1
5	Micro Switch	N/A	1
6	Retainer Clip	N/A	1
7	Body	N/A	1
8	O-ring (See 70-0306)	N/A Sep.	2
9	Back-up Ring (See 70-0306)	N/A Sep.	1
10	Piston	N/A	1
11	Washer	N/A	1
12	Spring	49-0144	1
13	Washer	N/A	1
14	Plastic Housing	N/A	1
15	O-ring (See 70-0306)	N/A Sep.	1
16	Nut	N/A	1
17	Wire Assembly	N/A	1
	O-ring Repair Kit (Inc. 4, 8-9, 15)	70-0306	

DETERGENT INJECTOR (50-0052)

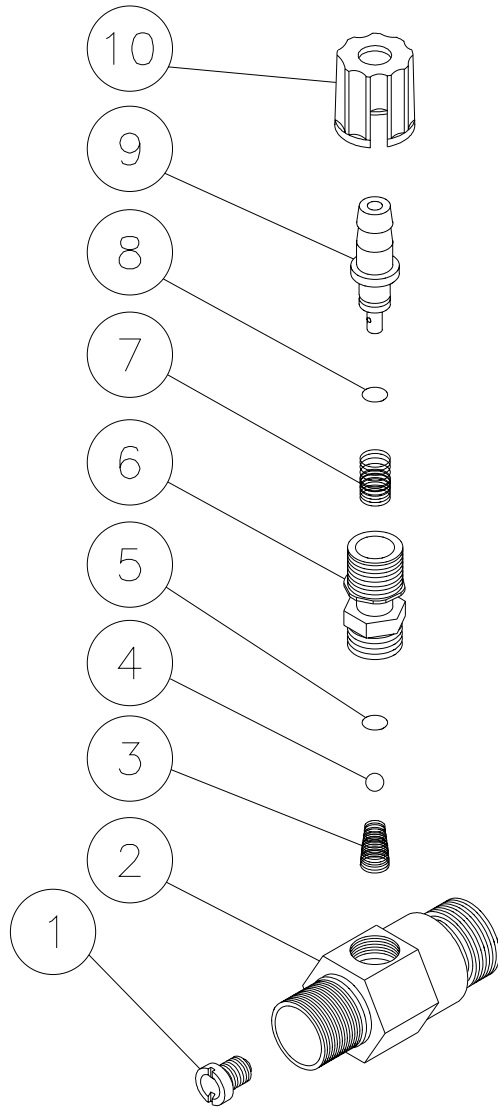

OMGEN284-052898-DCE

DETERGENT INJECTOR (50-0052)			
REF. #	DESCRIPTION	PART #	QTY.
1	Orifice (2.1mm)	50-0057	1
2	Injector Body	N/A	1
3	Spring (See 852-0056)	N/A Sep.	1
4	Ball (See 852-0056)	N/A Sep.	1
5	O-ring (See 852-0056)	N/A Sep.	1
6	Piston Retainer	50-0156	1
7	Spring	49-0056	1
8	O-ring (See 852-0056)	N/A Sep.	1
9	Adjustable Shutter Barb	50-0157	1
10	Adjustment Knob	50-0158	1
	Injector Repair Kit (Includes 3-5, 8)	852-0056	

COIL DRAIN PLUG (850-0218)

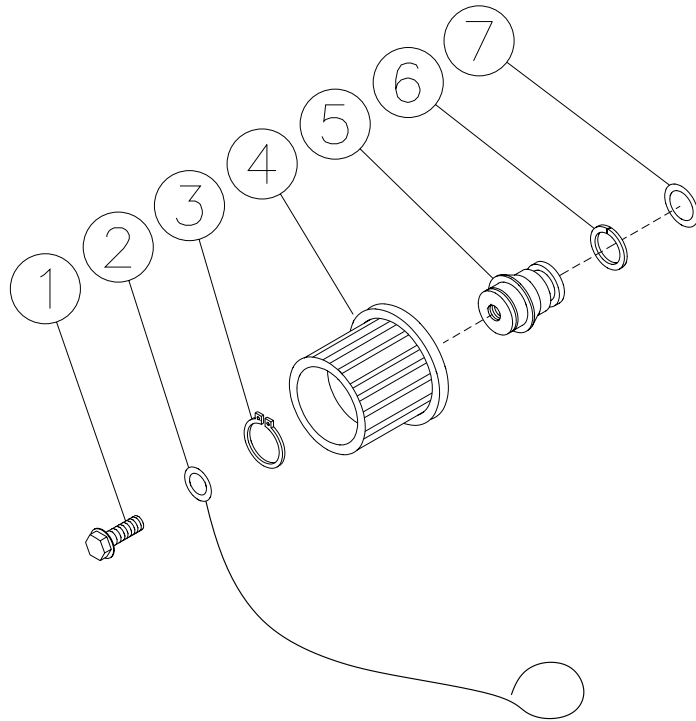

850-0218-041597-BAR

COIL DRAIN PLUG (850-0218)			
REF. #	DESCRIPTION	PART #	QTY.
1	Bolt	27-9526	1
2	Retaining Cable	33-0260	1
3	Snap Ring	33-0261	1
4	Hand Wheel	16-0239	1
5	Plug	24-0147	1
6	Back-up Ring	25-0424	1
7	O-ring	25-0423	1

850-0218-041597-BAR

HEAT EXCHANGER/EMF SYSTEM

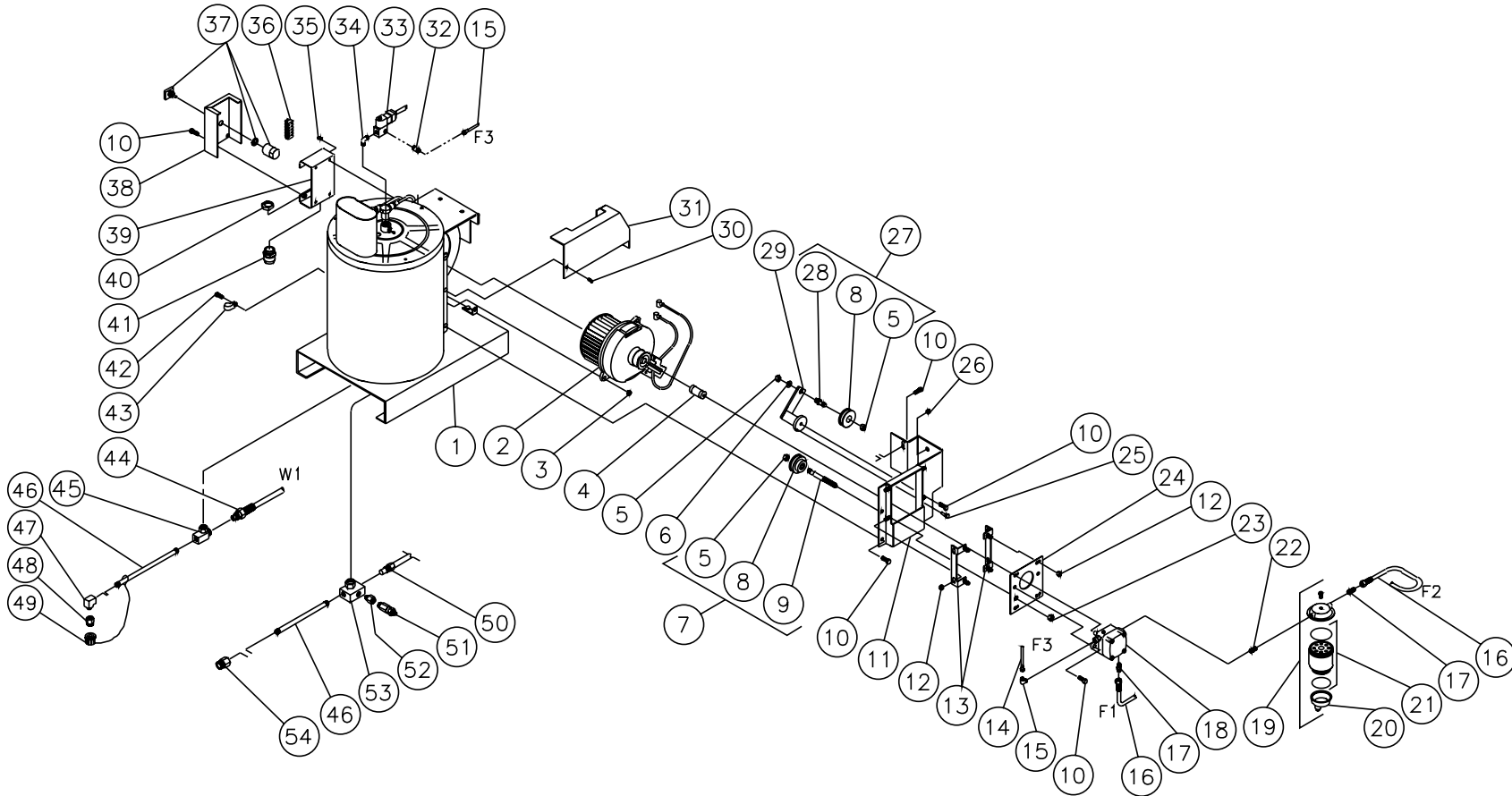

OMHSP086-011602-RD

HEAT EXCHANGER/ EMF SYSTEM							
REF. #	DESCRIPTION	PART #	QTY.	REF. #	DESCRIPTION	PART #	QTY.
1	Boiler Assembly Complete	850-0224	1	29	Tensioner Base	10-0071	1
2	EMF Assembly	850-0239	1	30	Bolt	27-9526	2
3	Hex Nut	30-3022	2	31	Beltguard- Black	20-0366A01	1
4	Fuel Pump Coupler	33-0225	1	32	Connector	23-0291	1
5	Nut	30-0159	3	33	Solenoid- 12 Volt	44-0098	1
6	Flatwasher	28-0022	1	34	Elbow	23-0249	1
7	Adjustable Sheave Shaft Assembly (Inc. 5, 8, 9)	850-0167	1	35	Bolt	27-9528	4
8	Sheave Assembly	850-0177	2	36	Terminal Stripe *(One Foot Required)	32-0394	1
9	Pulley	33-0221	1	37	Switch Cam	32-0399	1
10	Bolt	27-9524	11	38	Cover Electric Box- Black	20-0357A01	1
11	Bracket/ Fuel Pump- Black	20-0353A01	1	39	Backplate Electric Box- Black	20-0356A01	1
12	Hex Nut	30-3023	8	40	Electrical Locknut	32-0292	1
13	Bracket- Black	20-0360A01	2	41	Strain Relief	9-0046	1
14	Fuel Line	33-0217	1	42	Screw	27-3062	1
15	Elbow	23-0248	1	43	Cable Clamp	32-0428	1
16	Fuel Hose	15-0147	2	44	High Pressure Hose Assembly	15-0199	1
17	Connector	23-0247	2	45	Coil Inlet Connector Assembly	850-0225	1
18	Fuel Pump	3-0129	1	46	Nipple	24-0122	2
19	Filter Fuel Water Seperator	19-0070	1	47	Elbow	23-0034	1
20	Fuel Water Seperator Replacement Bowl	19-0071	1	48	Adapter	23-0279	1
21	Fuel Water Seperator Replacement Filter	19-0053	1	49	Drain Plug Assembly	850-0218	1
22	Hex Nipple	23-0250	1	50	High Limit Switch Probe	32-0421	1
23	Hex Nut	30-0010	1	51	Pressure Relief Valve	22-0273	1
24	Plate- Black	20-0363A01	1	52	Adapter Coil Outlet	23-0369	1
25	Pin	33-0211	1	53	Coil Outlet Assembly	850-0251	1
26	Hex Nut	30-0157	2	54	Hex Reducer	23-0197	1
27	Tensioner Sheave Shaft Assembly (Inc. 5, 8, 28)	850-0166	1	*Must Order in One Foot Lengths			
28	Shaft	33-0212	1				

BOILER ASSEMBLY (850-0224)

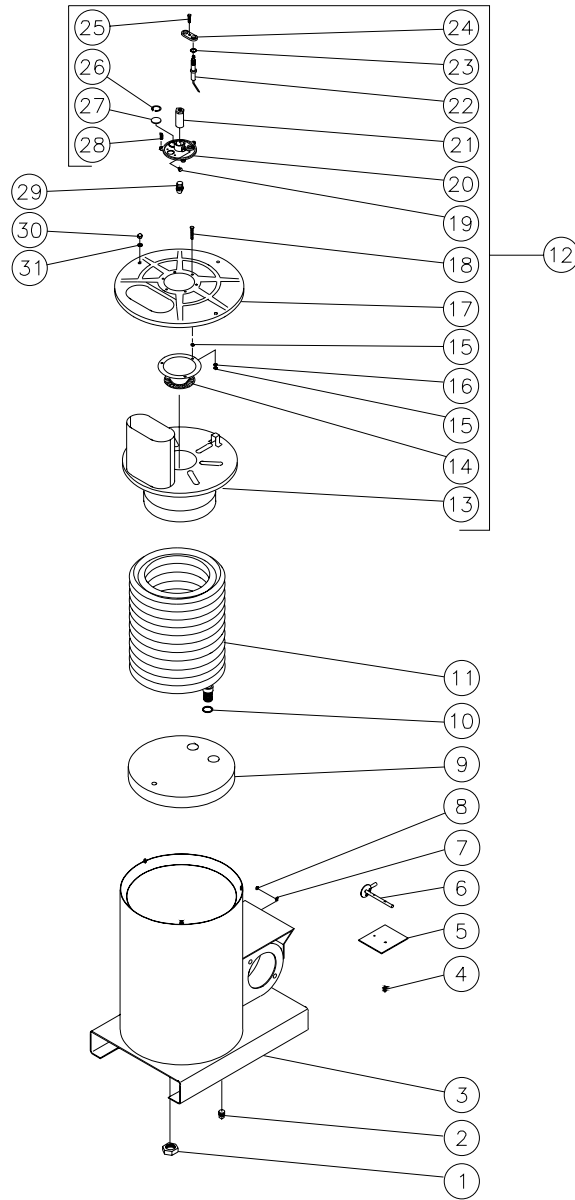

ELECTRODE GAP SETTINGS

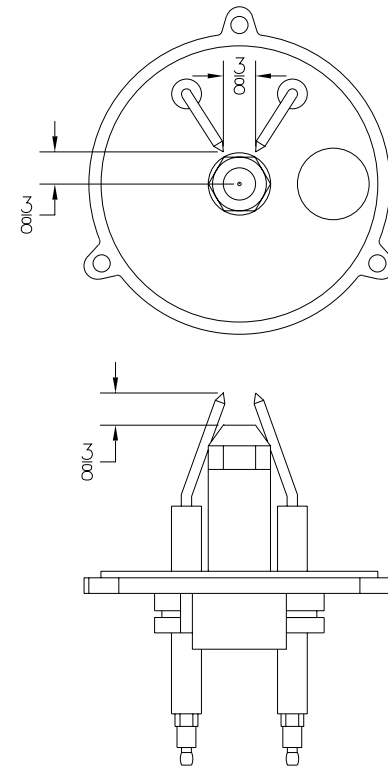

BOILER ASSEMBLY (850-0224)							
REF. #	DESCRIPTION	PART #	QTY.	REF. #	DESCRIPTION	PART #	QTY.
1	Hex Nut	30-6004	2	17	Top Pan	20-0323	1
2	Plug	24-0034	1	18	Bolt	27-8806	3
3	Heat Exchanger Assembly	20-0348A01	1	19	Bolt	27-8805	1
4	Bolt Hex Head	27-8879	2	20	Support Plate	33-0183	1
5	Air Diverter Plate	20-0454A01	1	21	Nozzle Holder	33-0182	1
6	Air Diverter Stem Assembly	20-0377A01	1	22	Electrode	32-0377	2
7	Lockwasher	28-1009	1	23	Washer	28-1007	2
8	Nut	30-6001	1	24	Electrode Mounting Plate	33-0180	1
9	Insulation	33-0267	1	25	Bolt	27-8807	1
10	Washer	28-0521	2	26	Snap Ring	25-0290	1
11	Heat Exchanger Coil Assembly	66-0010	1	27	Sight Glass	33-0179	1
12	Pan Assembly (Includes 13-28)	70-0184	1	28	Bolt	27-8803	3
13	Exhaust Pan	20-0324	1	29	Fuel Nozzle	18-0310	1
14	Heat Deflector	20-0325	1	30	Nut	30-6002	3
15	Nut	30-6001	6	31	Washer	28-1028	3
16	Lockwasher	28-1009	3		Boiler Assembly Complete (Inc. 1-28, 30, 31)	850-0224	1

GUN (850-0179) & ADJUSTABLE PRESSURE DUAL LANCE (850-0185)

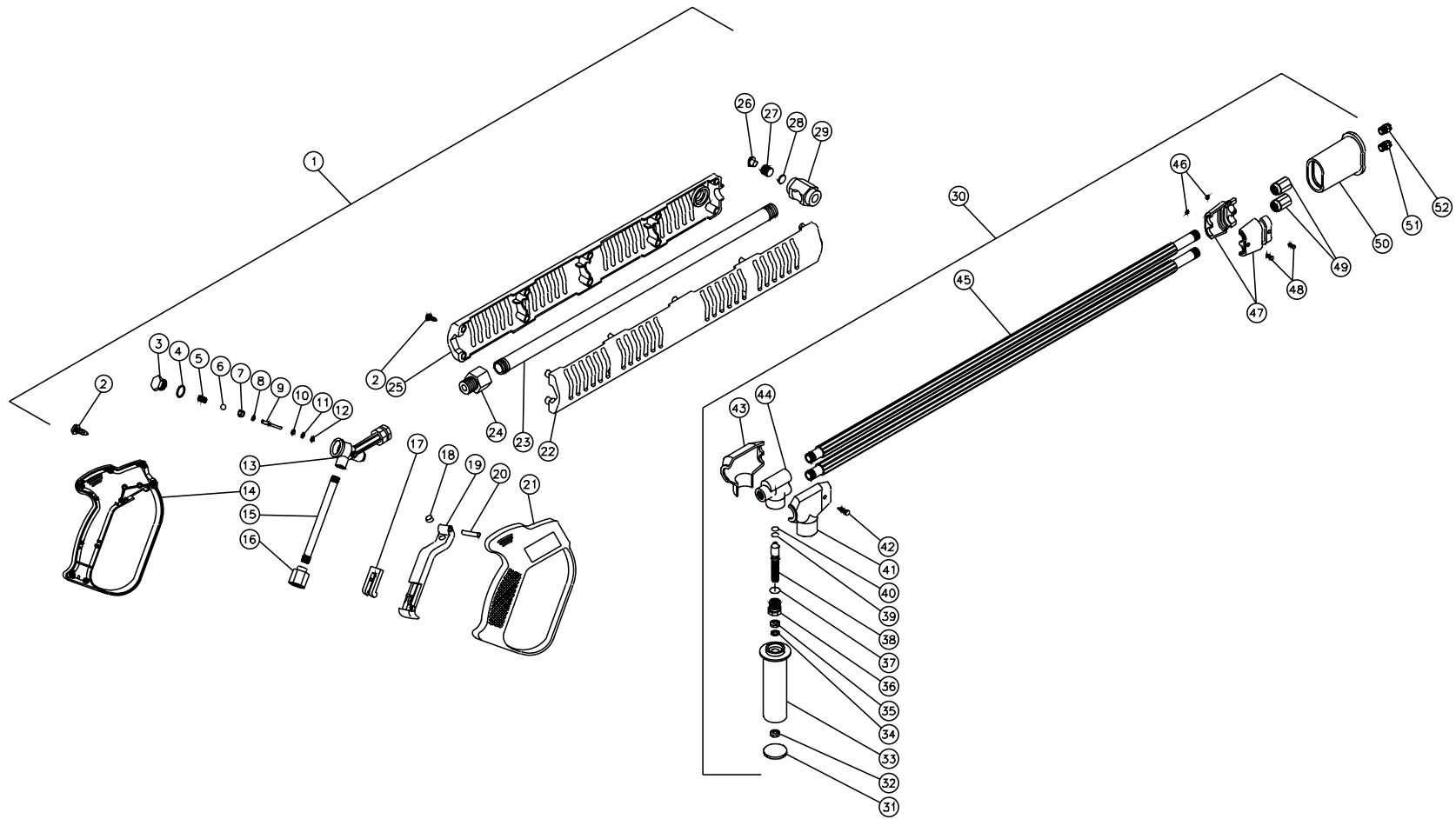

OMGEN256-101700-RD

GUNWAND (850-0179) & ADJUSTABLE PRESSURE DUAL LANCE (850-0185)							
REF. #	DESCRIPTION	PART #	QTY.	REF. #	DESCRIPTION	PART #	QTY.
1	Gun w/Lance Assembly (2-29)	850-0179	1	29	Lance Holder (See 850-0179)	N/A Sep.	1
2	Screw	27-8382	13	30	Adjustable Dual Lance Assembly (Includes 31-51)	850-0185	1
3	Plug (See 70-0057)	N/A Sep.	1	31	Handle Plug	16-0312	1
4	O-ring (See 70-0057)	N/A Sep.	1	32	Hex Nut	30-3002	1
5	Spring (See 70-0057)	N/A Sep.	1	33	Handle	16-0313	1
6	Ball (See 70-0057)	N/A Sep.	1	34	Washer	28-1021	1
7	Seat (See 70-0057)	N/A Sep.	1	35	Hex Nut	30-3010	1
8	O-ring (See 70-0057)	N/A Sep.	1	36	Hex Adapter	23-0271	1
9	Pin (See 70-0057)	N/A Sep.	1	37	O-ring	25-0351	1
10	Washer (See 70-0057)	N/A Sep.	1	38	Piston Stem	16-0314	1
11	O-ring (See 70-0057)	N/A Sep.	1	39	Back-up Ring	25-0352	1
12	Back-up Ring (See 70-0057)	N/A Sep.	1	40	O-ring	25-0353	1
13	Housing	23-0295	1	41	Upper Protector	16-0315	1
14	Plastic Housing (Left Side)	16-0336	1	42	Lower Protector	16-0316	1
15	Pipe	21-0095	1	43	Body	23-0272	1
16	Nipple	23-0174	1	44	Screw	27-8862	1
17	Trigger Safety Lock	16-0332	1	45	Lance w/Protective Cover	16-0328	2
18	Trigger Rest	16-0333	1	46	Hex Nut	30-3060	2
19	Trigger	16-0335	1	47	Pipe Clamp	16-0318	2
20	Trigger Pin	43-0069	1	48	Screw	27-8861	2
21	Plastic Housing (Right Side)	16-0334	1	49	Nipple	24-0127	2
22	Guard Lance (Right Side) (See 70-0324)	N/A Sep.	1	50	Nozzle Protector	16-0319	1
23	Pipe	16-0277	1	51	Nozzle-4060	18-0110	1
24	Adapter	16-0283	1	52	Nozzle-1503	18-0053	1
25	Guard Lance (Left Side) (See 70-0324)	N/A Sep.	1		Gun Repair Kit (Includes 3-12)	70-0057	
26	Plug	39-0076	1		O-ring Kit (Includes 37, 39, 40)	70-0143	
27	Screw	49-0103	1		Plastic Housing Kit (Includes 2, 22, 25, 26)	70-0324	
28	Spacer	16-0282	1				

FUEL TANK (850-0214)

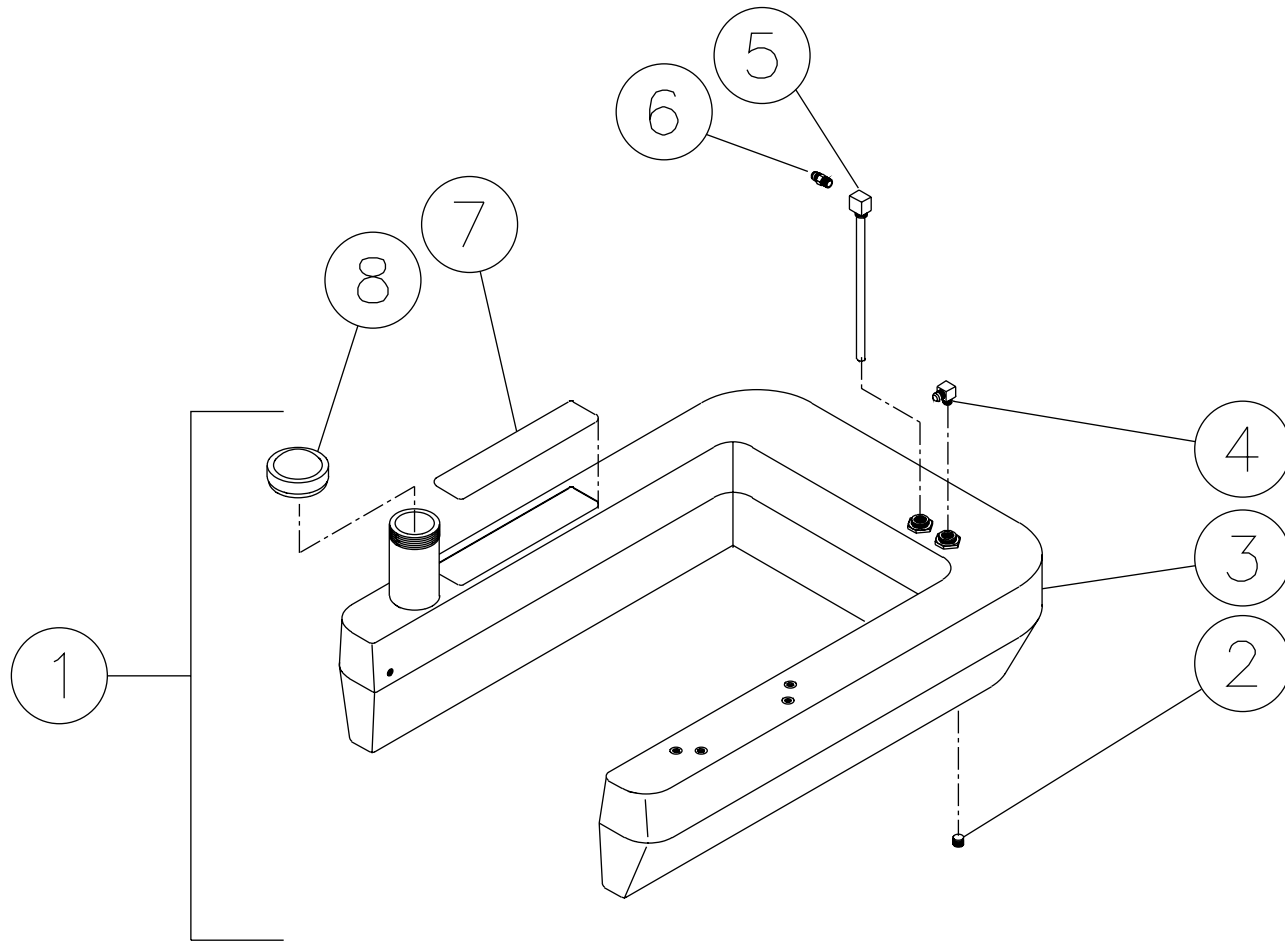

850-0214-34-9001-121797-BAR

FUEL TANK (850-0214)			
REF. #	DESCRIPTION	PART #	QTY.
1	Fuel Tank Assembly (Inc. 2-8)	850-0214	1
2	Plug	23-0296	1
3	Fuel Tank (See 850-0214)	N/A Sep.	1
4	Elbow	23-0237	1
5	Fuel Pick-up Line	33-0270	1
6	Flare	23-0247	1
7	Decal-Warning-Risk of Fire (E/S) (See 34-9001)	N/A Sep.	1
8	Vented Fuel Cap	12-0033	1
	Safety Decal Kit (Includes 7)	34-9001	

FUEL PUMP (3-0129)

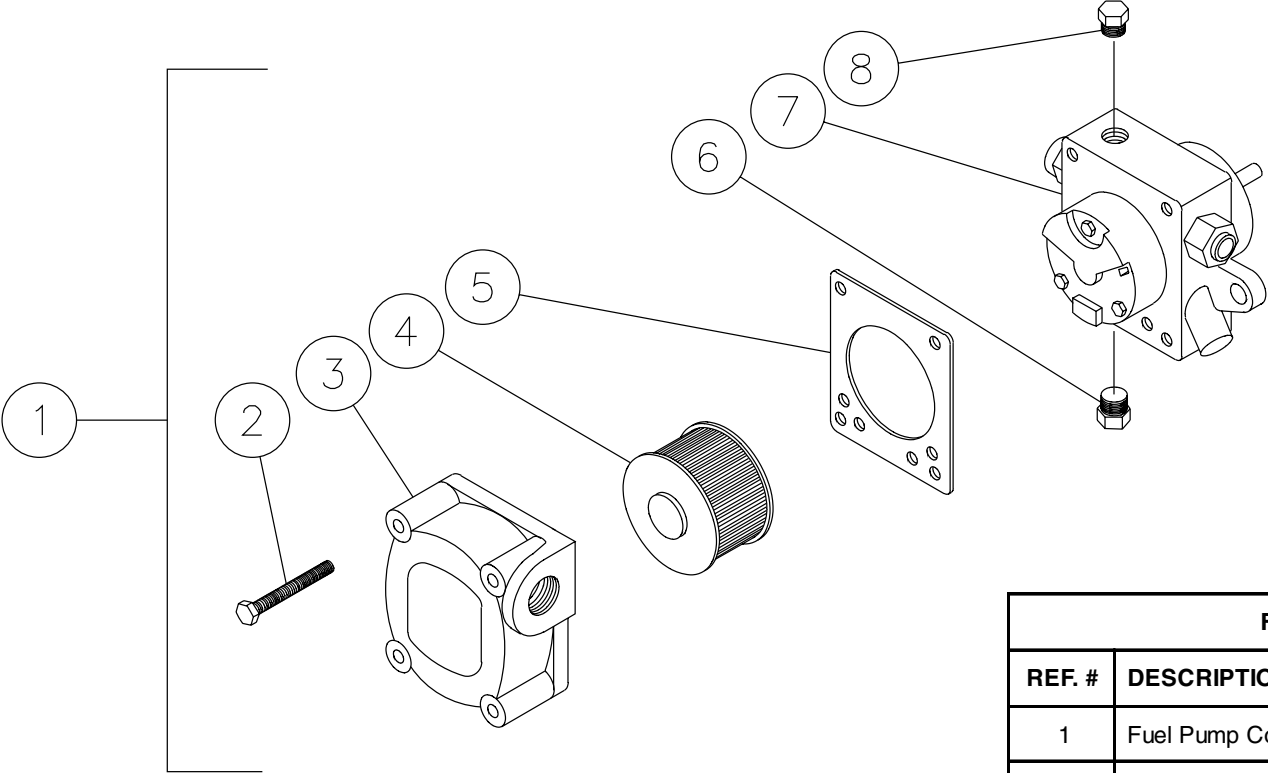

OMHSP018-041597-BAR

FUEL PUMP (3-0129)			
REF. #	DESCRIPTION	PART #	QTY.
1	Fuel Pump Complete (Includes 2-8)	3-0129	1
2	Cover Screw	46-1006	4
3	Cover-Left Hand	46-1018	1
4	Strainer	19-0034	1
5	Cover Gasket	26-0109	1
6	Plug	24-0044	3
7	Body	N/A	1
8	Plug	24-0082	1

OMHSP018/040694/BAR

FUEL SOLENOID (44-0098)

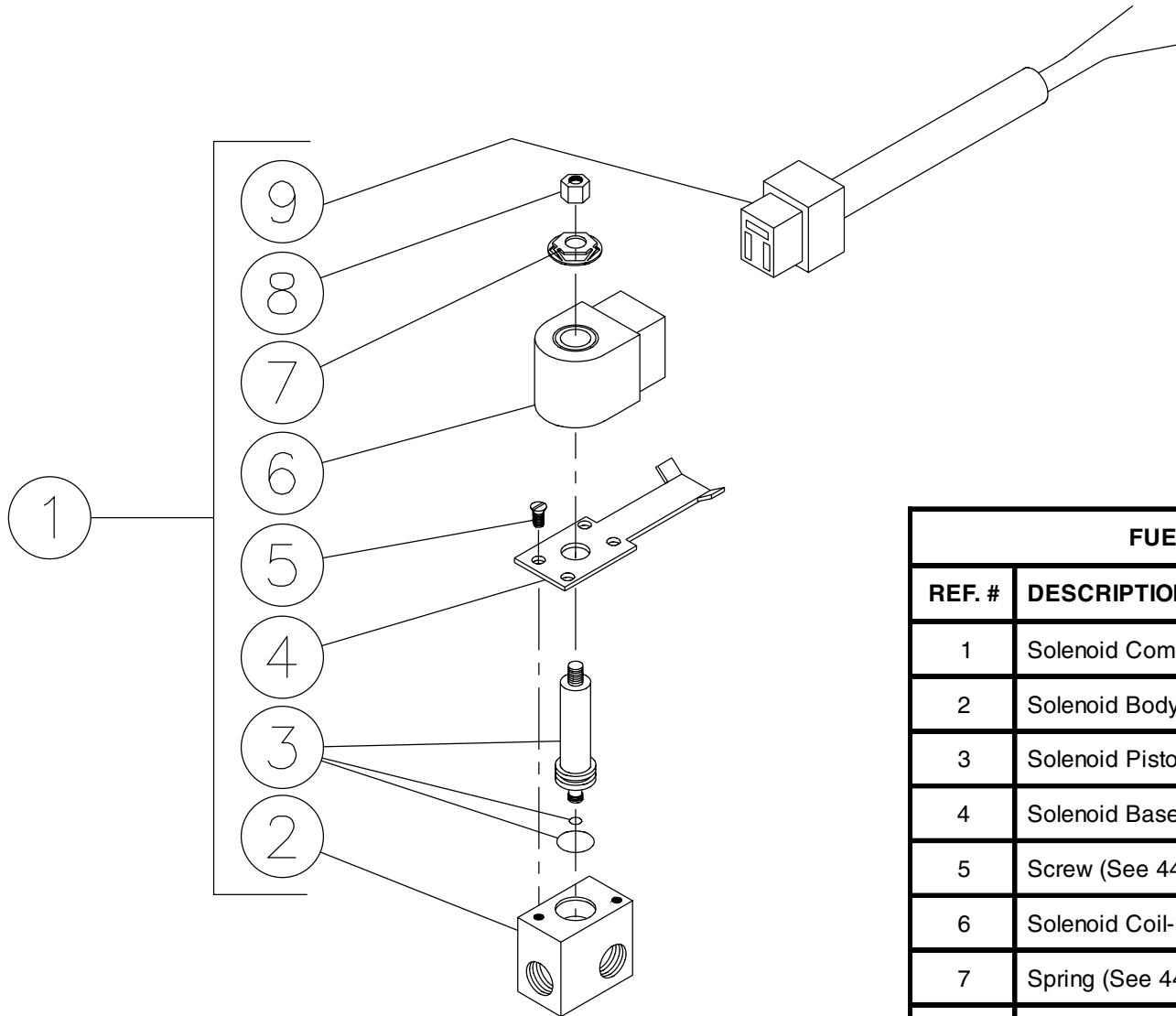

0MHSP013-44-0098-121698-BAR

FUEL SOLENOID (44-0098)			
REF. #	DESCRIPTION	PART #	QTY.
1	Solenoid Complete-12V	44-0098	1
2	Solenoid Body	46-1013	1
3	Solenoid Piston	46-1012	1
4	Solenoid Base	46-1014	1
5	Screw (See 44-0098)	N/A Sep.	2
6	Solenoid Coil-120V	46-1015	1
7	Spring (See 44-0098)	N/A Sep.	1
8	Piston Nut	46-1016	1
9	Din Connector Cord	32-0443	1

EMF SYSTEM (850-0239)

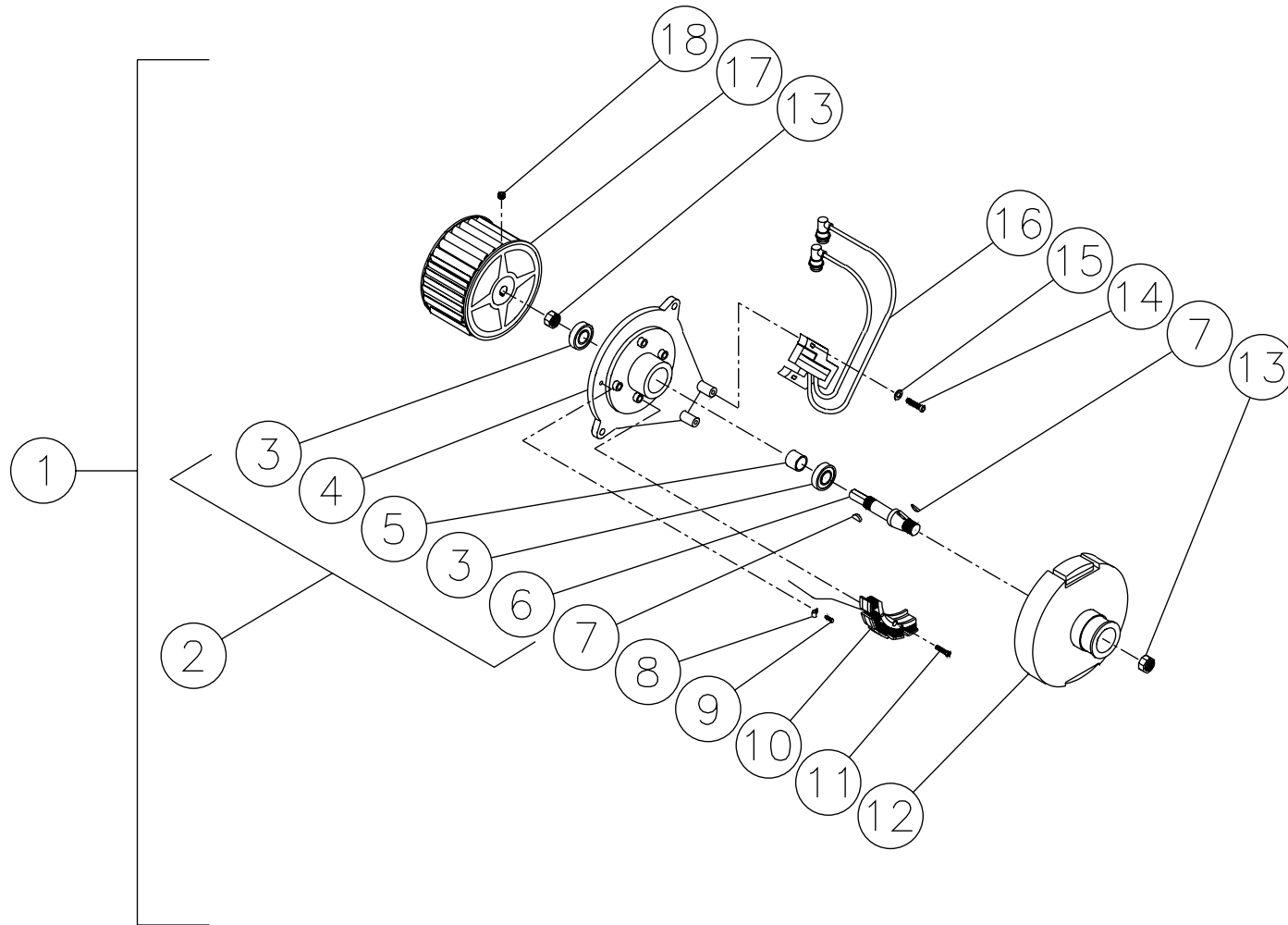

850-0239-113099-BAR

EMF SYSTEM (850-0239)			
REF. #	DESCRIPTION	PART #	QTY.
1	EMF Assembly Complete (Inc. 2-17)	850-0239	1
2	Blower Flange Assembly (Inc. 3-6)	850-0162	1
3	Sealed Bearing	48-0041	2
4	Blower Flange	38-0040	1
5	Spacer	33-0206	1
6	Blower Shaft	20-0347	1
7	Woodruff Key	43-0080	2
8	Cable Clamp	32-0403	1
9	Screw	27-2070	1
10	Stator Coil	850-0189	1
11	Screw	27-0740	4
12	Flange Magnet Hub	38-0041	1
13	Hex Nut	30-0177	2
14	Bolt	27-8898	2
15	Flatwasher	28-0002	2
16	Ignition Coil Assembly	850-0161	1
17	Blower Fan	44-0105	1
18	Set Screw	30-3021	1

WIRING SCHEMATIC

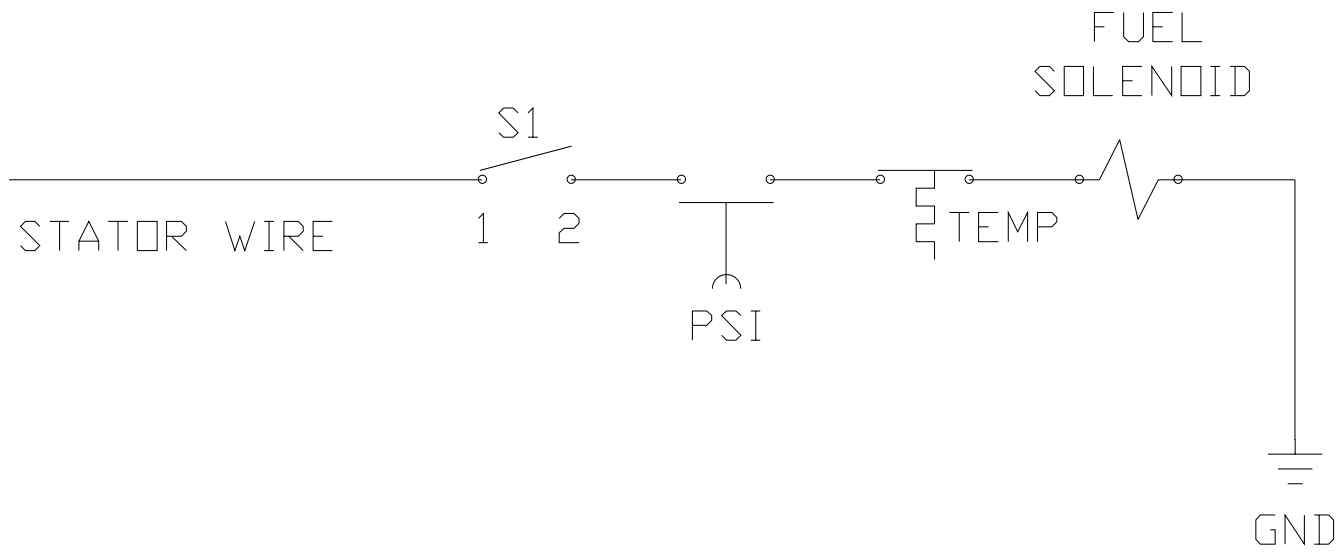

WIRING DIAGRAM

